

*AT FULL DIFFERENTIAL PRESSURE

SIZE	A	øD	E	F	G	J	øK1	øK2	øL1	øL2	ISO 5211	WEIGHT (lbs)	Cv	TORQUE* (in-lbf) TFM1600 SUPRALON	
2"	0.59 (15)	1.97 (50)	7.00 (178)	7.50 (190)	4.41 (112)	0.55 (14)	0.28 (7)	0.35 (9)	1.97 (50)	2.76 (70)	F05-F07	24	REFER TO VB41 DATA SHEET FOR Cv VALUES	371	598
3"	0.67 (17)	2.99 (76)	8.00 (203)	11.80 (300)	6.30 (160)	0.67 (17)	0.35 (9)	0.43 (11)	2.76 (70)	4.02 (102)	F07-F10	38		988	1572
4"	0.82 (21)	3.94 (100)	9.00 (229)	15.75 (400)	8.03 (204)	0.87 (22)	N/A	0.43 (11)	N/A	4.02 (102)	F10	69		1508	2400
6"	1.12 (28)	5.91 (150)	15.50 (394)	31.50 (800)	10.85 (275)	1.06 (27)	0.55 (14)	N/A	4.92 (125)	N/A	F12	161		6097	7926

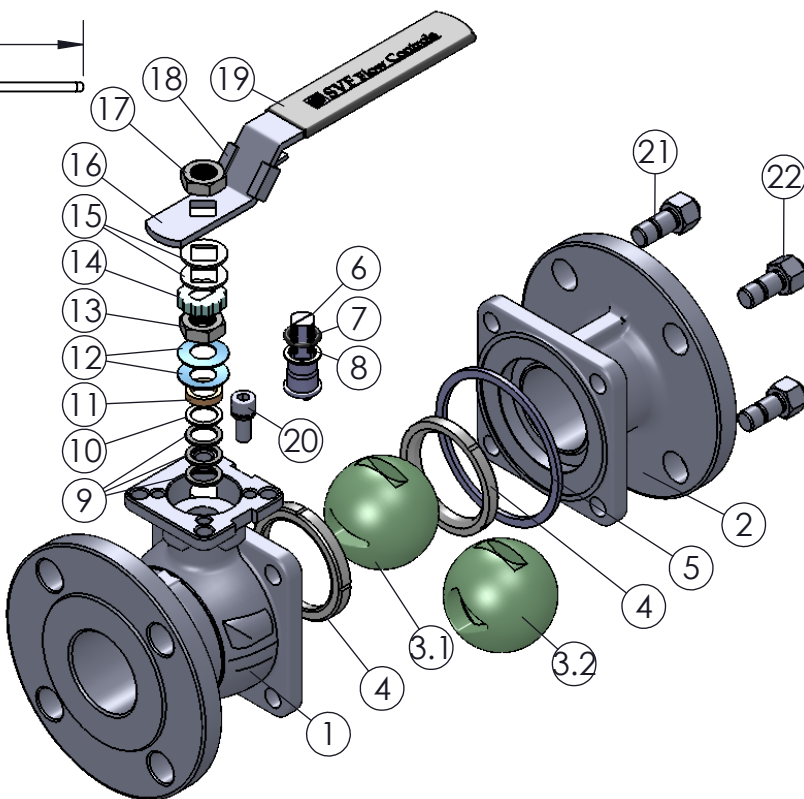

SIZES 3" - 6" WITH PIPE HANDLE:

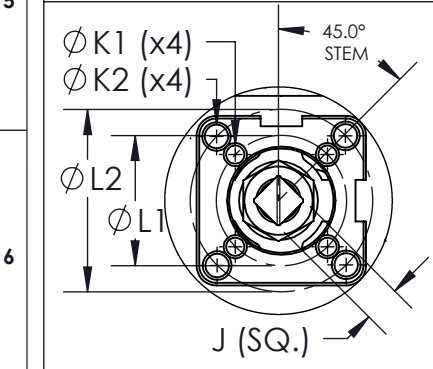
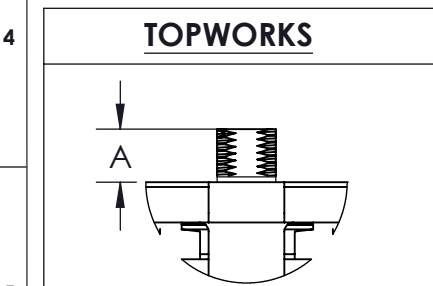
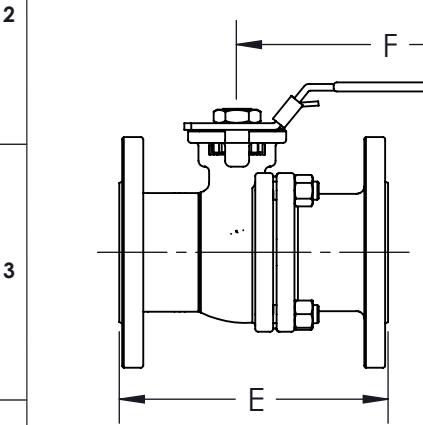
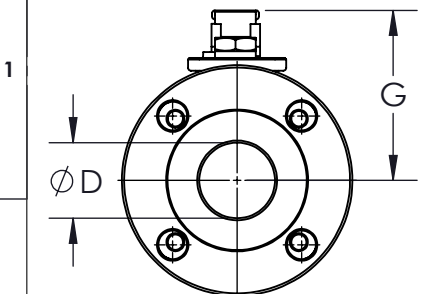
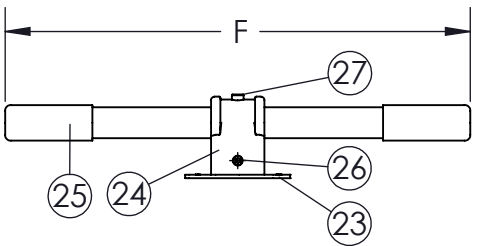

PRODUCT INFORMATION:

- LIVE-LOADED STEM PACKING
- STANDARD LOCKING HANDLE
- ANTI-STATIC DEVICE
- "V" BALL WITH 30° AND 60° V-PORT
- BALL IS VENTED ON THE STEM SLOT AREA
- COMPLETE VALVE AUTOMATION

OPTIONS:

- ISO STEM EXTENSION

APPLICABLE STANDARDS:

- NACE MR 0175
- ASME B16.34: DESIGN AND WALL THICKNESS
- ASME B16.10: FACE TO FACE
- ASME B16.5: END FLANGE
- API 598: INSPECTION AND TESTING
- AP1 607: FIRE SAFE
- ISO 5211: MOUNTING
- CGA G-4.1: CLEANING FOR OXYGEN SERVICE
- USP CLASS VI: CONFIRMATION OF COMPLIANCE (TFM1600/PTFE MATERIAL)

ITEM NO.	DESCRIPTION	MATERIALS		QTY.
1	BODY	A351-CF8M	A216-WCB	1
2	END	A351-CF8M	A216-WCB	1
3.1	BALL (30° V-PORT)	A351-CF8M		1
3.2	BALL (60° V-PORT)	A351-CF8M		1
4	SEAT	TFM1600	SUPRALON	2
5	BODY SEAL	316+GRAFOIL	PTFE	1
6	STEM	A276-316		1
7	O-RING	VITON		1
8	STEM THRUST WASHER	SUPRALON		1
9	STEM SEAL	GRAFOIL	PTFE	3
10	BUSHING	304 STAINLESS STEEL		1
11	GLAND FOLLOWER	316 STAINLESS STEEL		1
12	BELLEVILLE WASHER	301 STAINLESS STEEL		2
13	STEM NUT	A194-8		1
14	TAB LOCK	304 STAINLESS STEEL		1
15	HANDLE GLAND	304 STAINLESS STEEL		2
16	HANDLE (SIZE 2")	304 STAINLESS STEEL		1
17	HANDLE NUT	A194-8		1
18	LOCKING DEVICE (SIZE 2")	304 STAINLESS STEEL		1
19	HANDLE SLEEVE	PVC		1
20	STOP PIN	A193-B8		1
21	BODY BOLT	A193-B8		4
22	BODY NUT	A194-8		4
23	TRIANGULAR STOPPER (SIZES 3" - 6")	304 STAINLESS STEEL		1
24	PIPE HANDLE ADAPTER (SIZES 3" - 6")	A351-CF8		1
25	PIPE HANDLE (SIZES 3" - 6")	304 STAINLESS STEEL		1
26	PIPE HANDLE SET SCREW (SIZES 3" - 6")	A193-B8		1
27	ADAPTER SET SCREW (SIZES 3" - 6")	A193-B8		1

DRAWN BY C.L. DATE 07/07/2017
 CHECKED BY E.P. DATE 10/27/2017
 APPROVED BY J.S. DATE 10/27/2017
(FOR REF ONLY IF NOT APPROVED)

SVF Flow Controls
 5595 Fresca Drive • La Palma, CA 90623 • 1.800.783.7836
 www.SVF.net • Sales@SVF.net

DESCRIPTION:
 2" - 6" VB41 FLANGED BALL VALVE, ANSI CLASS 150, FULL PORT

PROJECTION THIRD ANGLE

UNITS: INCH (MILLIMETERS) DATE: 10/27/2017 REV: B