

* FULL PORT VALVES
 ** AT FULL DIFFERENTIAL PRESSURE FOR CLEAN FLUIDS WITH TFM1600 SEATS

SIZE	A	øB	C	øD	E	F	G	H1	øH2	J1	J2	K	øL	øM	øN	øO1	O2	NPT THREAD	ISO 5211	WEIGHT (lbs)	Cv	TORQUE** (in-lbf)	BODY BOLT SIZE	BODY NUT SIZE
1/4" *	0.21 (5)	1.0 (25)	0.37 (9)	0.44 (11)	2.60 (66)	5.0 (127)	1.8 (46)	1.5 (38)	1.8 (46)	0.22 (6)	0.37 (9)	M5-0.8	1.42 (36)	0.54 (14)	0.36 (9)	0.56 (14)	0.44 (11)	1/4"-18NPT	F03	2	3	45	M6-1.0 X 45	M6-1.0P
3/8" *	0.21 (5)	1.0 (25)	0.37 (9)	0.44 (11)	2.60 (66)	5.0 (127)	1.8 (46)	1.5 (38)	1.8 (46)	0.22 (6)	0.37 (9)	M5-0.8	1.42 (36)	0.68 (17)	0.49 (12)	0.69 (18)	0.44 (11)	3/8"-18NPT	F03	2	5	45	M6-1.0 X 45	M6-1.0P
1/2"	0.21 (5)	1.0 (25)	0.37 (9)	0.44 (11)	2.60 (66)	5.0 (127)	1.8 (46)	1.5 (38)	1.8 (46)	0.22 (6)	0.37 (9)	M5-0.8	1.42 (36)	0.84 (21)	0.62 (16)	0.86 (22)	0.44 (11)	1/2"-14NPT	F03	2	8	45	M6-1.0 X 45	M6-1.0P
3/4"	0.23 (6)	1.0 (25)	0.37 (9)	0.56 (14)	2.81 (71)	5.0 (127)	1.9 (48)	1.5 (38)	1.8 (46)	0.22 (6)	0.37 (9)	M5-0.8	1.42 (36)	1.05 (27)	0.82 (21)	1.07 (27)	0.56 (14)	3/4"-14NPT	F03	2	12	45	M6-1.0 X 50	M6-1.0P
1"	0.34 (9)	1.2 (30)	0.70 (18)	0.81 (20)	3.70 (94)	6.0 (152)	2.4 (61)	1.7 (43)	2.1 (53)	0.30 (8)	0.43 (11)	M5-0.8	1.65 (42)	1.32 (34)	1.05 (27)	1.33 (34)	0.56 (14)	1"-11.5NPT	F04	4	32	100	M8-1.25 X 65	M8-1.25P
1-1/4"	0.34 (9)	1.2 (30)	0.93 (24)	1.00 (25)	4.25 (108)	6.0 (152)	2.6 (66)	1.7 (43)	2.1 (53)	0.30 (8)	0.43 (11)	M5-0.8	1.65 (42)	1.66 (42)	1.38 (35)	1.68 (43)	0.53 (13)	1-1/4"-11.5NPT	F04	5	57	130	M8-1.25 X 75	M8-1.25P
1-1/2"	0.40 (10)	1.4 (36)	1.18 (30)	1.25 (32)	4.57 (116)	7.0 (178)	3.2 (81)	2.1 (53)	2.6 (66)	0.34 (9)	0.56 (14)	M6-1.0	1.97 (50)	1.90 (48)	1.61 (41)	1.92 (49)	0.53 (13)	1-1/2"-11.5NPT	F05	7	80	280	M10-1.5 X 85	M10-1.5P
2"	0.40 (10)	1.4 (36)	1.18 (30)	1.50 (38)	5.04 (128)	7.0 (178)	3.3 (84)	2.1 (53)	2.6 (66)	0.34 (9)	0.56 (14)	M6-1.0	1.97 (50)	2.38 (60)	2.07 (53)	2.41 (61)	0.68 (17)	2"-11.5NPT	F05	11	104	360	M10-1.5 X 95	M10-1.5P
2-1/2"	0.42 (11)	1.4 (36)	1.22 (31)	2.00 (51)	5.95 (151)	11.0 (279)	3.4 (86)	2.1 (53)	2.6 (66)	0.34 (9)	0.56 (14)	M6-1.0	1.97 (50)	2.88 (73)	2.47 (63)	2.94 (75)	1.06 (27)	2-1/2"-8NPT	F05	17	240	560	M10-1.5 X 120	M10-1.5P

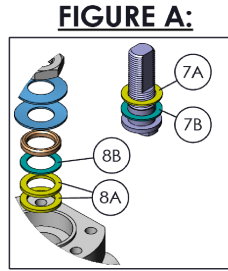
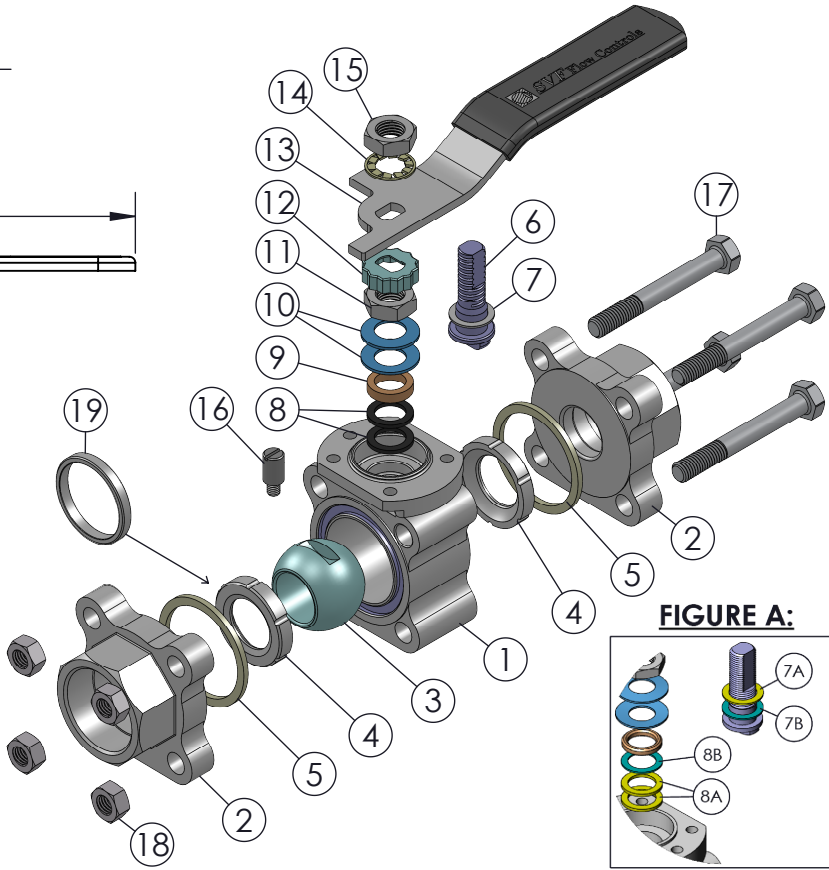
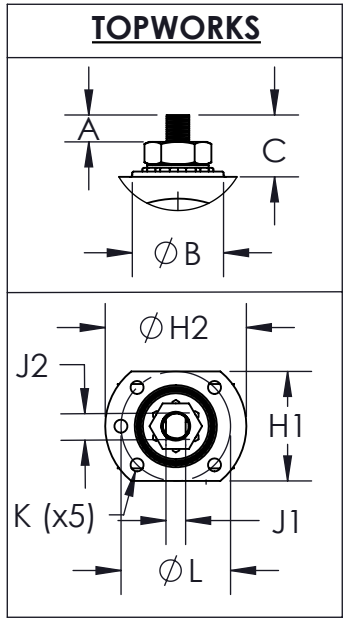
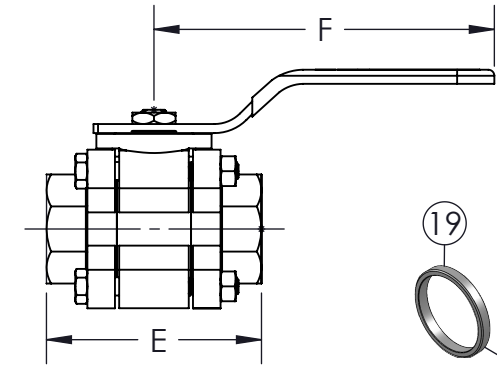
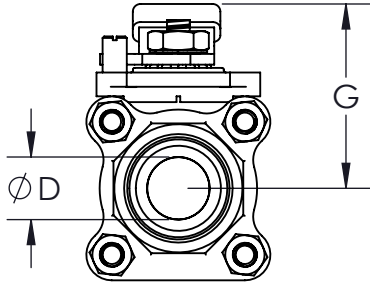

PRODUCT INFORMATION:
 1. END CONNECTIONS AVAILABLE IN: SCREWED (FNPT), SOCKET WELD, BUTT WELD, SCREWED x SOCKET WELD, SCREWED x BUTT WELD (SCH-40 OR SCH-10)
 2. SERVICES INCLUDE: OXYGEN CLEANING, DEGREASING, VENT/RELIEF HOLE, AMMONIA SERVICE, HIGH CYCLE STEM KIT AND VACUUM & SEARCHING GAS STEM KIT
 3. BALL IS VENTED ON THE STEM SLOT AREA
 4. ALL STAINLESS STEEL PASSIVATED
 5. MANGANESE PHOSPHATE COATING ON WCB CARBON STEEL
 6. 2-1/2" R8 VALVE REQUIRES 17-4PH (ASTM A564-630) STEM AS STANDARD COMPONENT
 7. COMPLETE VALVE AUTOMATION
 8. SVF OFFERS VIRGIN PEEK THRUST WITH TFM SEALS FOR APPLICATIONS WHERE CARBON BLENDS ARE NOT ACCEPTABLE AS A WETTED COMPONENT. (SEE FIGURE A)

OPTIONS:
 1. OVAL HANDLE
 2. LOCKING DEVICE
 3. ISO STEM EXTENSION
 4. ANTI-STATIC DEVICE

APPLICABLE STANDARDS:
 1. ASME B16.34: DESIGN
 2. API 598: INSPECTION AND TESTING
 3. ISO 5211: MOUNTING
 4. ANSI B1.20.1: NPT
 5. ANSI B16.11: FORGED STEEL FITTINGS, SOCKET-WELDING
 6. ANSI B16.25: BUTT WELD ENDS
 7. CGA G-4.1: CLEANING FOR OXYGEN SERVICE
 8. USP CLASS VI: CONFIRMATION OF COMPLIANCE (TFM1600/PTFE MATERIAL)
 9. ANSI CLASS 600 RATING APPLIES TO 1/4" - 2" R8 VALVES WITH TFM1600 SEATS

ITEM NO.	DESCRIPTION	MATERIALS	QTY.
1	BODY	A351-CF8M A216-WCB A351-CN7M A494 CW-12MW	1
2	END	A351-CF3M A216-WCB A351-CN7M A494 CW-12MW	2
3	BALL	A351-CF8M A351-CN7M B164-N0440 A494 CW-12MW	1
4	SEAT	TFM1600 DELRIN UHMWPE PEEK	2
5	BODY SEAL	PTFE SUPRALON UHMWPE BUNA "N" VITON EPDM GRAFOIL	2
6	STEM	A276-316 A351-CN7M B164-N0440 A564-630 A494 CW-12MW	1
7	STEM THRUST WASHER	SUPRALON DELRIN PEEK UHMWPE	1
7A	STEM THRUST WASHER	TFM1600	1
7B	STEM THRUST WASHER	VIRGIN PEEK	1
8	STEM SEAL	SUPRALON UHMWPE	2
8A	STEM SEAL	TFM1600	2
8B	STEM SEAL	VIRGIN PEEK	1
9	GLAND FOLLOWER	304 STAINLESS STEEL	1
10	BELLEVILLE WASHER	17-7 PH STAINLESS STEEL	2
11	JAM NUT	304 STAINLESS STEEL	1
12	LOCK TAB	304 STAINLESS STEEL	1
13	LEVER HANDLE	304 STAINLESS STEEL	1
14	SERRATED LOCK WASHER	304 STAINLESS STEEL	1
15	HANDLE NUT	304 STAINLESS STEEL	1
16	STOP PIN	304 STAINLESS STEEL	1
17	BODY BOLT	304 STAINLESS STEEL	4
18	BODY NUT	304 STAINLESS STEEL	4
19	SEAT RETAINER (2-1/2" ONLY)	316 STAINLESS STEEL	1

DRAWN BY: E.P. DATE: 04/04/2017
 CHECKED BY: DATE: 03/22/2018
 APPROVED BY: J.S. DATE: 03/22/2018

SVF Flow Controls
 5595 Fresca Drive • La Palma, CA 90623 • 1.800.783.7836
 www.SVF.net • Sales@SVF.net

DESCRIPTION:
 1/4" - 3/8" R8 3-PIECE BALL VALVE, FULL PORT &
 1/2" - 2-1/2" R8 3-PIECE BALL VALVE, STANDARD PORT

UNITS: INCH (MILLIMETERS) DATE: 01/21/2019 REV: E

* AT FULL DIFFERENTIAL PRESSURE FOR CLEAN FLUIDS WITH TFM1600 SEATS

SIZE	A	øB	C	øD	E	F	G	H1	H2	J1	K1	K2	øL1	L2	øM	øN	øO1	O2	NPT THREAD	ISO 5211	WEIGHT (lbs)	Cv	TORQUE* (in-lbf)	BODY BOLT SIZE
3"	0.77 (20)	1.98 (50)	1.98 (50)	2.50 (64)	6.68 (170)	14.0 (356)	7.3 (182)	3.78 (96)	4.02 (102)	0.75 (19)	M10x1.5P	0.39 (10)	4.02 (102)	1.89 (48)	3.58 (91)	3.06 (78)	3.54 (90)	0.68 (17)	3" NPT	F10	30	320	1000	M10 - 1.5 X30

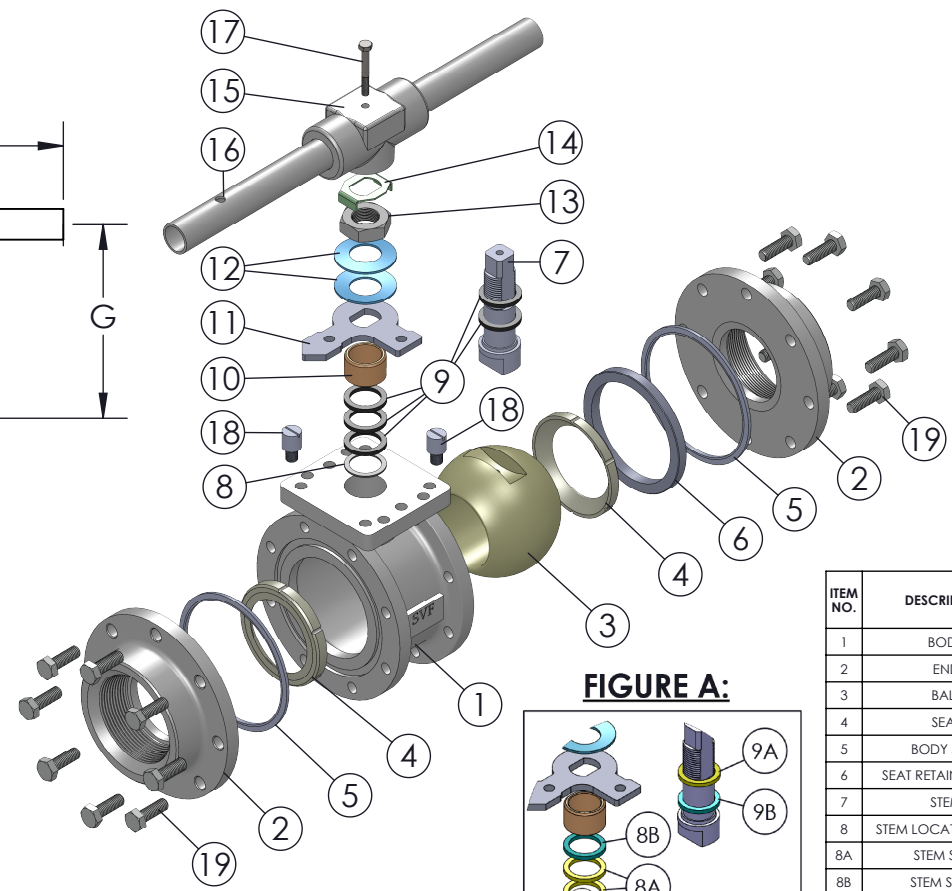
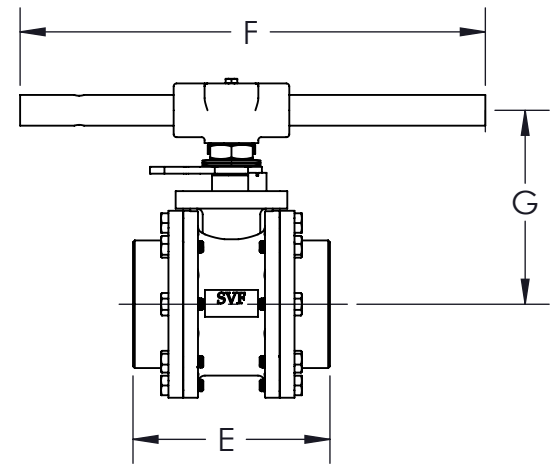

PRODUCT INFORMATION:
 1. END CONNECTIONS AVAILABLE IN: SCREWED (FNPT), SOCKET WELD, BUTT WELD, SCREWED x SOCKET WELD, SCREWED x BUTT WELD (SCH-40 OR SCH-10)
 2. SERVICES INCLUDE: OXYGEN CLEANING, DEGREASING, VENT/RELIEF HOLE, AMMONIA SERVICE, HIGH CYCLE STEM KIT, AND VACUUM & SEARCHING GAS STEM KIT
 3. BALL IS VENTED ON THE STEM SLOT AREA
 4. ALL STAINLESS STEEL PASSIVATED
 5. MANGANESE PHOSPHATE COATING ON WCB CARBON STEEL
 6. LOCKING DEVICE IS A STANDARD COMPONENT
 7. COMPLETE VALVE AUTOMATION
 8. SVF OFFERS VIRGIN PEEK THRUST WITH TFM SEALS FOR APPLICATIONS WHERE CARBON BLENDS ARE NOT ACCEPTABLE AS A WETTED COMPONENT. (SEE FIGURE A)

OPTIONS:
 1. ISO STEM EXTENSION
 2. ANTI-STATIC DEVICE

APPLICABLE STANDARDS:
 1. ASME B16.34: DESIGN
 2. API 598: INSPECTION AND TESTING
 3. ISO 5211: MOUNTING
 4. ANSI B1.20.1: NPT
 5. ANSI B16.11: FORGED STEEL FITTINGS, SOCKET-WELDING
 6. ANSI B16.25: BUTT WELD ENDS
 7. CGA G-4.1: CLEANING FOR OXYGEN SERVICE
 8. USP CLASS VI: CONFIRMATION OF COMPLIANCE (TFM1600/PTFE MATERIAL)

FIGURE A:

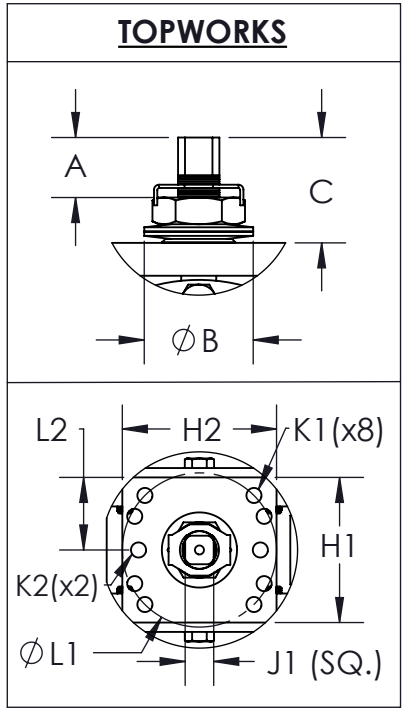
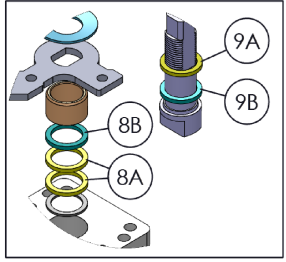

END CONFIGURATIONS:

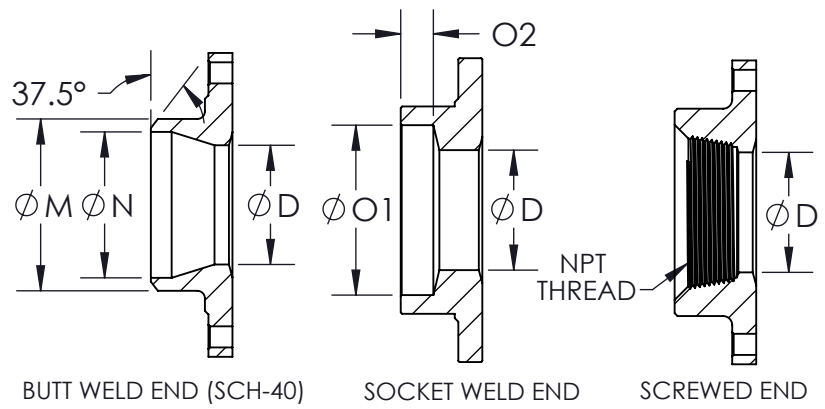

ITEM NO.	DESCRIPTION	MATERIALS				QTY.
1	BODY	A351-CF8M	A216-WCB	A351-CN7M	A494 CW-12MW	1
2	END	A351-CF3M	A216-WCB	A351-CN7M	A494 CW-12MW	2
3	BALL	A351-CF8M	A351-CN7M	B164-N0440	A494 CW-12MW	1
4	SEAT	TFM1600 DELRIN UHMWPE PEEK				2
5	BODY SEAL	PTFE SUPRALON	UHMWPE BUNA "N"	VITON EPDM	GRAFOIL	2
6	SEAT RETAINER RING	304 STAINLESS STEEL				1
7	STEM	A276-316	A351-CN7M	B164-N0440	A564-630 A494 CW-12MW	1
8	STEM LOCATION RING	316 STAINLESS STEEL				1
8A	STEM SEAL	TFM1600				2
8B	STEM SEALS	VIRGIN PEEK				1
9	STEM THRUST WASHER	SUPRALON UHMWPE				5
9A	STEM THRUST WASHER	TFM1600				1
9B	STEM THRUST WASHER	VIRGIN PEEK				1
10	GLAND FOLLOWER	304 STAINLESS STEEL				1
11	LOCKING PLATE	316 STAINLESS STEEL				1
12	BELLEVILLE WASHER	17-7 PH STAINLESS STEEL				2
13	STEM NUT	304 STAINLESS STEEL				1
14	LOCK TAB	304 STAINLESS STEEL				1
15	HANDLE ADAPTER	316 STAINLESS STEEL				1
16	PIPE HANDLE	316 STAINLESS STEEL				1
17	HANDLE BOLT	304 STAINLESS STEEL				1
18	STOP PIN	304 STAINLESS STEEL				2
19	BODY BOLT	304 STAINLESS STEEL				16

DRAWN BY E.P. DATE 04/04/2017
 CHECKED BY E.G. DATE 03/22/2018
 APPROVED BY J.S. DATE 03/22/2018
(FOR REF ONLY IF NOT APPROVED)
 THE INFORMATION CONTAINED IN THIS DRAWING IS THE SOLE PROPERTY OF SVF FLOW CONTROLS, INC. ANY REPRODUCTION IN PART OR IN WHOLE WITHOUT THE WRITTEN CONSENT OF SVF FLOW CONTROLS, INC. IS PROHIBITED.

SVF Flow Controls
 5595 Fresca Drive • La Palma, CA 90623 • 1.800.783.7836
 www.SVF.net • Sales@SVF.net

DESCRIPTION:
 3" R8 3-PIECE BALL VALVE, STANDARD PORT

UNITS: INCH (MILLIMETERS) DATE: 01/21/2019 REV: D