

INSTALLATION, OPERATION & MAINTENANCE FOR SVF SERIES EZ9 BALL VALVES



GENERAL

SVF Ball valves have been designed and engineered to provide long lasting and trouble free service when used in accordance with the instructions and specifications herein.

The following instructions refer only to SVF Series EZ9 Ball Valves.

Keep protective cover in place until moment of installation. Valve performance depends upon preventing of damage to ball surface. Upon removal of cover, make sure that the valve is completely open and free of obstruction.

If requested, valves can be shipped from the factory containing a silicon based lubricant which aids in the assembly of the valve. This may be removed with a solvent if found intolerable.

Certain ferrous valves are phosphate and oil dipped during the course of manufacture, but they are completely non-toxic and the valves are quite safe to use for edible or potable products.

STORAGE:

All manual valves are shipped in the fully open position with protective end caps (covers). Keep all protective packaging, flange covers, or end caps attached to the valves during storage. To avoid damage to the seat due to contact with the balls edge, leave the valve in the **fully open or closed position** during storage. It is recommended to keep the valves in a clean and dry environment until ready for use.

!!!CAUTION! Safety Precautions!!!

Before removing valve from pipeline NOTE that:

Media flowing through a valve may be corrosive, toxic, flammable, a contaminant or harmful nature. Where there is evidence of harmful fluids having flowed through the valve, the utmost care must be taken. It is suggested that the following minimal safety precautions be taken when handling valves.

1. Always wear eye shields.
2. Always wear gloves and overalls.
3. Wear protective footwear.
4. Wear protective headgear.
5. Ensure that running water is readily accessible.
6. Have a suitable fire extinguisher ready if media is flammable.
7. Be sure that you are aware of the fluid that has been passing through the valve before opening or dismantling any valve. Require MSDS information.

By checking line gauges ensure that no pressure is present at the valve.

Ensure that any media is released by operating valve slowly to half open position. Ideally, the valve should be decontaminated when the ball is in the half open position.

These valves, when installed, have body connectors which form an integral part of the pipeline and the valve cannot be removed from the pipeline without being dismantled.

Valves and accessories must not be used as a sole support of piping or human weight. Safety accessories such as safety relief (overpressure) valves are the responsibility of the system designer.

It is the user/system designer's responsibility to use insulation in high temperature applications. Refer to OSHA documents for more details.

What do you need today?™

INSTALLATION, OPERATION & MAINTENANCE FOR SVF SERIES EZ9 BALL VALVES**INSTALLATION**

The valve may be installed for flow or vacuum in either direction. Carefully exclude pipe sealants from the valve cavity. When installing, use standard gaskets suitable for the specific service. Tighten flange bolts or studs evenly.

OPERATION

SVF valves provide tight shut off when used under normal conditions and in accordance with SVF's published pressure/temperature chart. If these valves are used in a partially open (throttled) position seat life may be reduced.

SVF valves have ¼ turn operation closing in a clockwise direction. It is possible to see when the valve is open or closed by the position of the wrench handle. When the wrench is in line with the pipeline, the valve is open.

Any media which might solidify, crystallize or polymerize should not be allowed to stand in the ball valve cavities unless regular maintenance is provided. If minimal maintenance is required, SVF offers steam jacketed ball valves.

TORQUE REQUIREMENTS

Torque ratings are subject to variations depending on the length of time between cycles and the media in the system.

Breakaway torque is that force which must be exerted to cause the ball to begin to open. Operating torque requirements will vary depending on the length of time between cycles, media in the system, line pressure and type of valve seat.

MAINTENANCE

With self-wiping ball/seats, SVF valves have a long, trouble free life, and maintenance is seldom required. But, when necessary, valves may be refurbished, using a small number of components, none of which require machining.

SVF valves are designed for easy service and assembly in the field. The following checks will help to extend valve life, or reduce plant problems.

SVF ball valves utilize live-loaded stem seals featuring Belleville washers (disk springs) that maintain constant pressure on the Stem Seal area even under a wide range of pressure and temperature fluctuations. If stem leakage is evident proceed as follows:

STEM LEAKAGE

Examine the disk springs (Belleville washers) for damage. If in good condition tighten the gland nut until disk springs are firmly compressed, then back nut off 1/16th of a turn. If damaged, dismantle the stem down to the gland, fit new disk springs with their outer edges touching, replace and retighten using gland nut. Further maintenance necessitates dismantling of the valve.

LEAKAGE AT BODY JOINT

Check for tightness at the body connector bolts. If loose, tighten body bolts. Excessive force will damage the bolts. (See Table A below)
If there is still leakage it will be necessary to dismantle the valve and replace the body seals.

IN-LINE LEAKAGE

Check that the valve is fully closed. If leakage occurs while the valve is in the closed position, a seat or ball sealant surface may be damaged and it will be necessary to disassemble the valve.

NOTE: If Stem leakage and leakage at body joint are not cured by the simple means described above, it will be necessary to dismantle the valve. If there is no stem leakage the stem assembly should not be touched.



INSTALLATION, OPERATION & MAINTENANCE FOR SVF SERIES EZ9 BALL VALVES

REBUILDING

Before rebuilding, check that all the correct components are available and that they are fit for reassembly. When rebuilding, cleanliness is essential to allow long valve life and provide cost effective maintenance. CAUTION: NO BODY OR STEM SEALS ARE REUSABLE. Care must be taken to avoid scratching the seats and seals during installation.

NOTE: Caution must be taken with valves that have been in hazardous media. They must be decontaminated before disassembly by relieving the line pressure and flushing the line with the valve in the partially open position. Protective clothing, face shields, gloves, etc., MUST BE USED for this operation.

A DISASSEMBLY OF VALVE (Removed from line)

- 1.) Remove the End Connectors (#2) by removing the Body Bolts (#14) and Body Bolt Nuts (#15).
- 2.) Once the End Connectors (#2) have been separated from the Body (#1), remove the Seats (#5).
- 3.) Make sure the Ball (#3) is in the closed position, thus the Ball (#3) can be taken out easily from the Body (#1).

B REMOVING STEM ASSEMBLY

- 1.) Remove Handle (#11) by removing Handle Nut (#12).
- 2.) Remove the Stem Nut (#10), Tab Lock (#9), Belleville Washers (#8), Gland (#7), and Stem Seals (#6).
- 3.) Push the Stem (#4) down into the body cavity to remove. Once removed take off the O-Ring (#17) and Thrust Washer (#18).

C INSPECTION

- 1.) The ball and the surfaces against which the seats wipe and make contact should be free of pit marks and scratches. Light marring from the action of the ball against the seats is normal and will not affect the operation of the valve.
- 2.) The stem and body surfaces, which the thrust washer and Stem Seals make contact with, should be free of pit marks and scratches.

D REASSEMBLY

- 1.) Apply an adequate amount of lubricant compatible with the media being handled around the Ball (#3), Seats (#5), Stem (#4), Thrust Washer (#18), and O-Ring (#17).
- 2.) For stem reassembly, disassembly procedure should be followed in reverse order.
- 3.) When stem assembly is complete, tighten Stem Nut according to the values in Table A.
- 4.) With the Stem (#4) in the close position, insert the Ball (#3) into Body (#1) so that stem slot engages with the tang at the base of the stem.
- 5.) Insert Seats (#5) into the Body (#1).
- 6.) Merge the End Connectors (#2) with the Body (#1).
- 7.) Insert and tighten Body Bolts (#14), Body Nuts (#15), and Body Washers (#16), in accordance to the cross pattern procedure shown on the following page.
- 8.) In the final assembly step ensure that the Body Bolts (#14) and Body Bolt Nuts (#15) are tightened to torque values according to Table A.

See Page 5 for additional information on installing the valve handle.

INSTALLATION, OPERATION & MAINTENANCE FOR SVF SERIES EZ9 BALL VALVES

TORQUE SPECS

Certain precautions need to be followed when tightening bolts down to their corresponding torques to help prevent bolt galling. There are two passes each bolt has to undergo during the process, first pass and the final pass. Once every bolt has met the first pass requirement, the final pass can be initiated. When tightening down bolts it is necessary to follow the corresponding bolt pattern shown below.

REPAIR KITS

Repair Kits are available from SVF Flow Controls, Inc. Table B below shows what the kits consist of. When ordering a Repair Kit, please be sure to specify the type, size and seating material of the valve.

When repairing a valve use only SVF Flow Controls, Inc. authorized spare parts including; bolts and nuts, etc. In addition to maintenance kits, spare parts are available from SVF Flow Controls, Inc. They are: balls, stems and glands. If additional parts are required (body and ends) it is normally recommended that the complete valve be replaced.

Components from a different valve series should not be used with the repair of any other valve. If the valve is altered in any way, no liability can be accepted by SVF Flow Controls, Inc.

TABLE A: TORQUE REQUIREMENTS (in-lbs)

Valve Size	Bolt Pattern	Body Bolts		Stem Nuts
		First Pass	Final Pass	
1/4"	4	96	160	35
3/8"	4	96	160	35
1/2"	4	96	160	35
3/4"	4	96	160	80
1"	4	96	160	80
1-1/4"	4	168	280	80
1-1/2"	4	168	280	250
2"	4	198	380	250

TABLE B: GENERAL REPAIR KIT

Part	Quantity
Thrust Washer	1
Stem Seals	2
Belleville Washers	2
One piece Seats/Body Seals	2
O-Ring	1

EZ9 SERIES BOLT PATTERN - BOLT TIGHTENING SEQUENCE

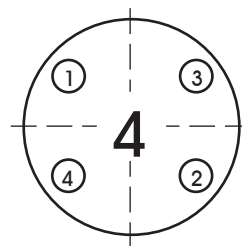

MATERIALS OF CONSTRUCTION FOR SVF SERIES EZ9 BALL VALVES

Item #	Part Name	Materials	Recommended Spare	Wetted
1	Body	316 Stainless Steel A351-CF8M	-	X
2	End Connectors	ASTM-A351 CF8M ASTM-A216 WCB	-	X
3	Ball	316 Stainless Steel	-	X
4	Stem	316 Stainless Steel	-	X
5	One Piece Seats/Body Seals	TFM1600™	X	X
6	Stem Seals	RTFE	X	-
7	Gland	304 Stainless Steel	X	X
8	Belleville Washers	401 Stainless Steel	X	-
9	Tab Lock	304 Stainless Steel	X	-
10	Stem Nut	304 Stainless Steel	-	-
11	Handle	304 Stainless Steel	-	-
12	Handle Nut	304 Stainless Steel	-	-
13	Locking Device	304 Stainless Steel	-	-
14	Body Bolt	304 Stainless Steel	-	-
15	Body Bolt Nut	304 Stainless Steel	-	-
16	Body Bolt Washer	304 Stainless Steel	-	-
17	O-Ring	Viton®	X	X
18	Thrust Washer	RTFE	X	X

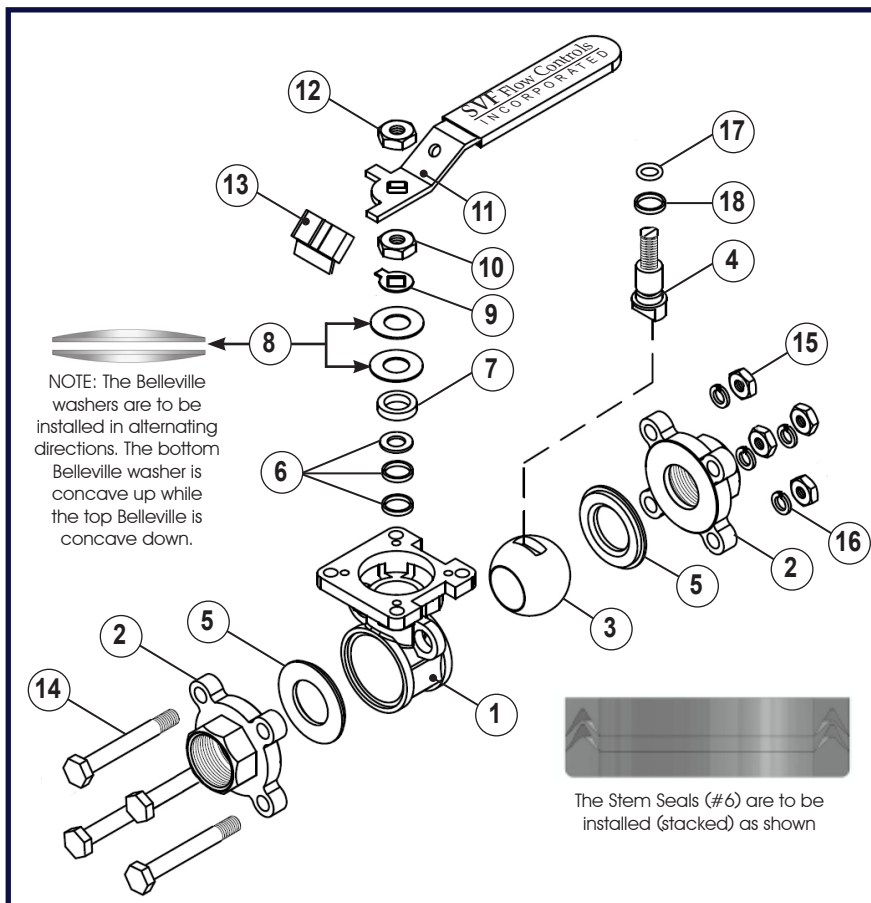

VALVE HANDLE INSTALLATION

NOTE: After valve assembly is completed, install the valve handle parallel to the groove on the top of the stem as shown.

Slide the Handle (#11) over the top of the Stem (#4) and tighten the Handle Nut (#12)

