

*AT FULL DIFFERENTIAL PRESSURE FOR CLEAN FLUIDS WITH RTFE SEATS

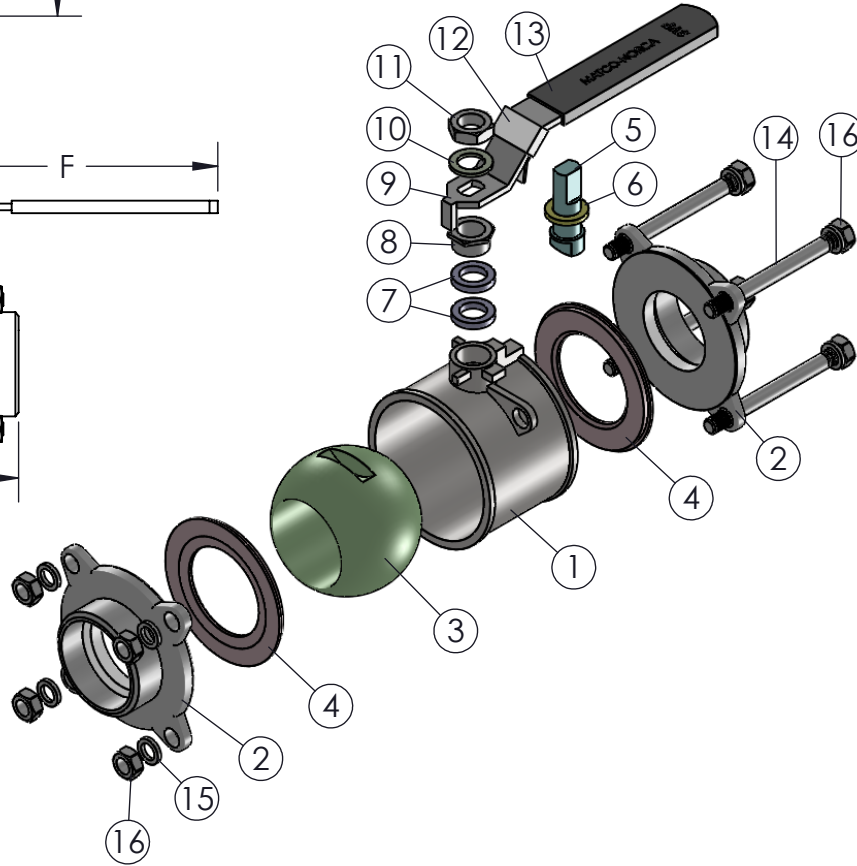
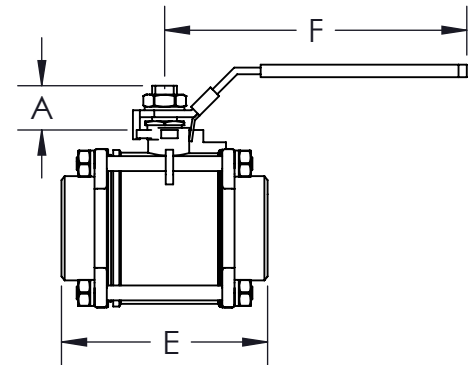
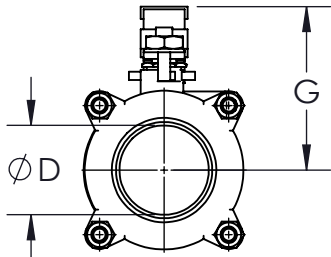

FASTENER KIT TABLE:

SIZES	BOLTS	WASHERS	NUTS
1/4" - 2"	4	4	4
2-1/2"	4	8	8
3" - 4"	6	12	12

NOTE: FASTENER KIT ABOVE 2" VALVES WILL USE STUB BOLTS

END CONFIGURATIONS:

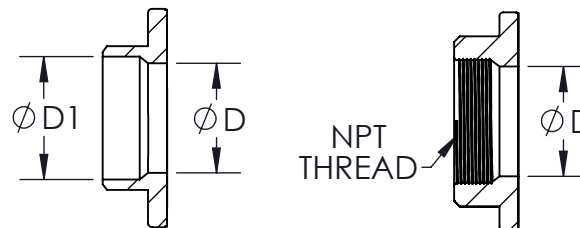

SOCKET WELD END

SCREWED END

SIZE	A	øD	øD1	E	F	G	NPT THREAD	WEIGHT (lbs)	Cv
1/4"	0.55 (14)	0.46 (12)	0.55 (14)	1.81 (46)	3.22 (82)	1.85 (47)	1-4"-18NPT	0.5	6
3/8"	0.55 (14)	0.49 (13)	0.67 (17)	1.81 (46)	3.22 (82)	1.85 (47)	3/8"-18NPT	0.5	8
1/2"	0.67 (17)	0.59 (15)	0.87 (22)	2.16 (55)	3.42 (87)	2.09 (53)	1/2"-14NPT	1	11
3/4"	0.67 (17)	0.79 (20)	1.06 (27)	2.56 (65)	3.78 (96)	2.24 (57)	3/4"-14NPT	1	21
1"	0.79 (20)	0.98 (25)	1.34 (34)	2.83 (72)	4.76 (121)	2.68 (68)	1"-11.5NPT	2	34
1-1/4"	0.79 (20)	1.26 (32)	1.65 (42)	3.38 (86)	4.76 (121)	2.87 (73)	1-1/4"-11.5NPT	3	57
1-1/2"	0.94 (24)	1.50 (38)	1.93 (49)	3.97 (101)	6.06 (154)	3.22 (82)	1-1/2"-11.5NPT	4	80
2"	0.94 (24)	1.97 (50)	2.40 (61)	4.53 (115)	6.06 (154)	3.70 (94)	2"-11.5NPT	7	148
2-1/2"	1.26 (32)	2.48 (63)	3.03 (77)	5.90 (150)	8.66 (220)	4.68 (119)	2-1/2"-8NPT	13	265
3"	1.26 (32)	2.99 (76)	3.50 (89)	6.61 (168)	8.66 (220)	5.12 (130)	3" NPT	21	415
4"	1.50 (38)	3.78 (96)	4.53 (115)	8.07 (205)	11.97 (304)	5.78 (147)	4" NPT	39	780

PRODUCT INFORMATION:

- 1. END CONNECTIONS AVAILABLE IN: SCREWED END (FNPT) AND SOCKET WELD END
- 2. 1/4" - 4" FULL PORT
- 3. BALL IS VENTED ON THE STEM SLOT AREA
- 4. BLOW-OUT PROOF STEM
- 5. STANDARD LOCKING HANDLE
- 6. ANTI-STATIC DEVICE

APPLICABLE STANDARDS:

- 1. ASME B16.34: DESIGN
- 2. API 598: INSPECTION AND TESTING
- 3. ANSI B1.20.1: NPT
- 4. ANSI B1.6.11: COMPLIANT FOR SOCKET WELD
- 5. USP CLASS VI: CONFIRMATION OF COMPLIANCE (PTFE MATERIAL)

ITEM NO.	DESCRIPTION	MATERIALS	QTY.
1	BODY	A351-CF8M A216-WCB	1
2	END	A351-CF8M A216-WCB	1
3	BALL	A351-CF8M	1
4	SEAT	RTFE	2
5	STEM	A276-316	1
6	STEM THRUST WASHER	PTFE	1
7	STEM SEAL	PTFE	2
8	HANDLE NUT	304 STAINLESS STEEL	1
9	HANDLE	430 STAINLESS STEEL	1
10	SPRING WASHER	304 STAINLESS STEEL	1
11	HANDLE NUT	304 STAINLESS STEEL	1
12	LOCKING DEVICE	430 STAINLESS STEEL	1
13	HANDLE SLEEVE	PVC	1
14	BOLT	304 STAINLESS STEEL	REFER TO FASTENER KIT TABLE
15	SPRING WASHER	304 STAINLESS STEEL	
16	HEX NUT	304 STAINLESS STEEL	

DRAWN BY E.P. DATE 06/23/2017
 CHECKED BY E.G. DATE 03/22/2018
 APPROVED BY J.S. DATE 03/22/2018
(FOR REF. ONLY IF NOT APPROVED)



THE INFORMATION CONTAINED IN THIS DRAWING IS THE SOLE PROPERTY OF SVF FLOW CONTROLS, INC. ANY REPRODUCTION IN PART OR AS A WHOLE WITHOUT THE WRITTEN CONSENT OF SVF FLOW CONTROLS, INC. IS PROHIBITED.

PROJECTION THIRD ANGLE

DESCRIPTION:
 1/4" - 4" EZ6 3-PIECE FULL PORT BALL VALVE

UNITS: INCH (MILLIMETERS) DATE: 03/22/2018 REV: C